

FR03 Specification

Lithium Iron Disulfide Primary Cylindrical Battery

(Li / FeS₂) 1.5V, 1100mAh

Model No.		FR03
Nominal Voltage		1.5V
Nominal Capacity (mAh) (Discharging at 300mA)		1100mAh
Working Voltage (Discharging at 100mA)		1.30V
Weight		7.7g
Maximum Dimension	Diameter	10.0±0.5mm
	Height	43.9±0.6mm
Max. Discharge Current	Continuous	1000mA
Cut-off Voltage		0.8V
Operating Temperature Range		-20°C to 60°C
Storage Temperature Range		-20°C to 40°C
Storage Humidity		≤75%

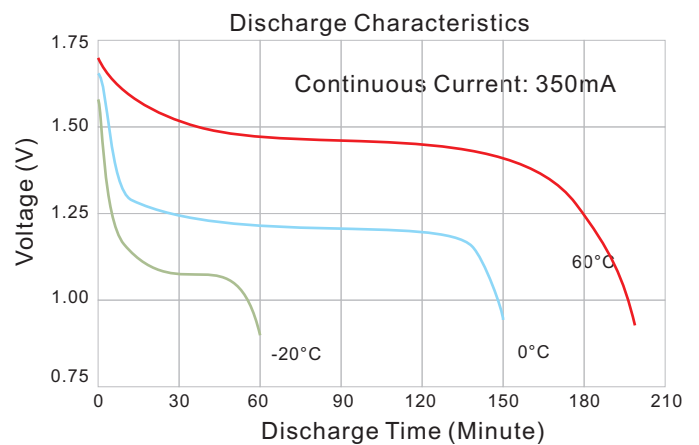
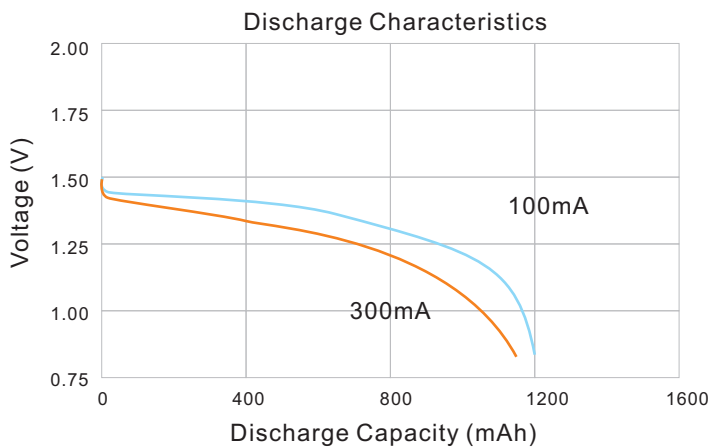
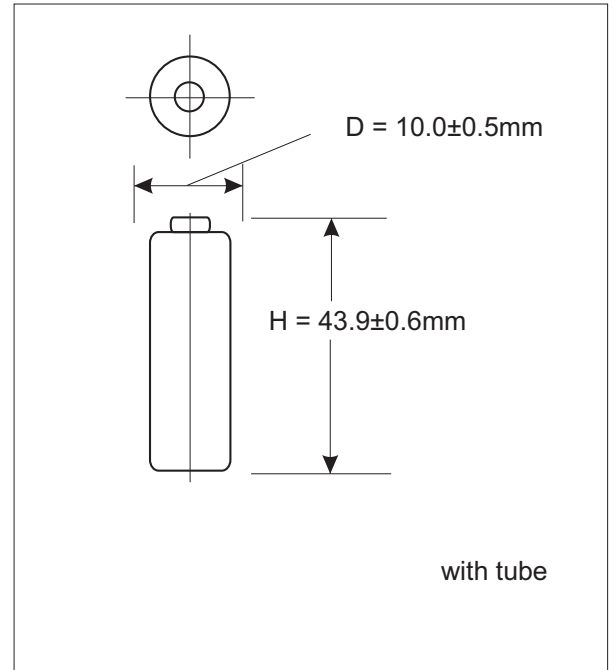

**Note: The data in this document are for descriptive purposes only and subject to change without prior notice.